

©1968 BY AMP INCORPORATED. ALL RIGHTS RESERVED. AMP PRODUCTS COVERED BY PATENTS AND/OR PATENTS PENDING.

Unpublished copy not to be reproduced without written permission of AMP Inc.

ZONE	LTR	DESCRIPTION	DATE	APPROVED
	0	NPS 67-0579 (REV 3)	7-1-68	RHW
	A	REV TITLE PER ECN PC-5545	12-6-68	RHW
	B	REMOVED ENGINEERING CONT. P-6288 REVISED P-6293	4-17-70	FCY
	C	REVISED PER ECN P-6489	9-18-71	FCY
	D	REV PER G-5318	10/25/89	WSV

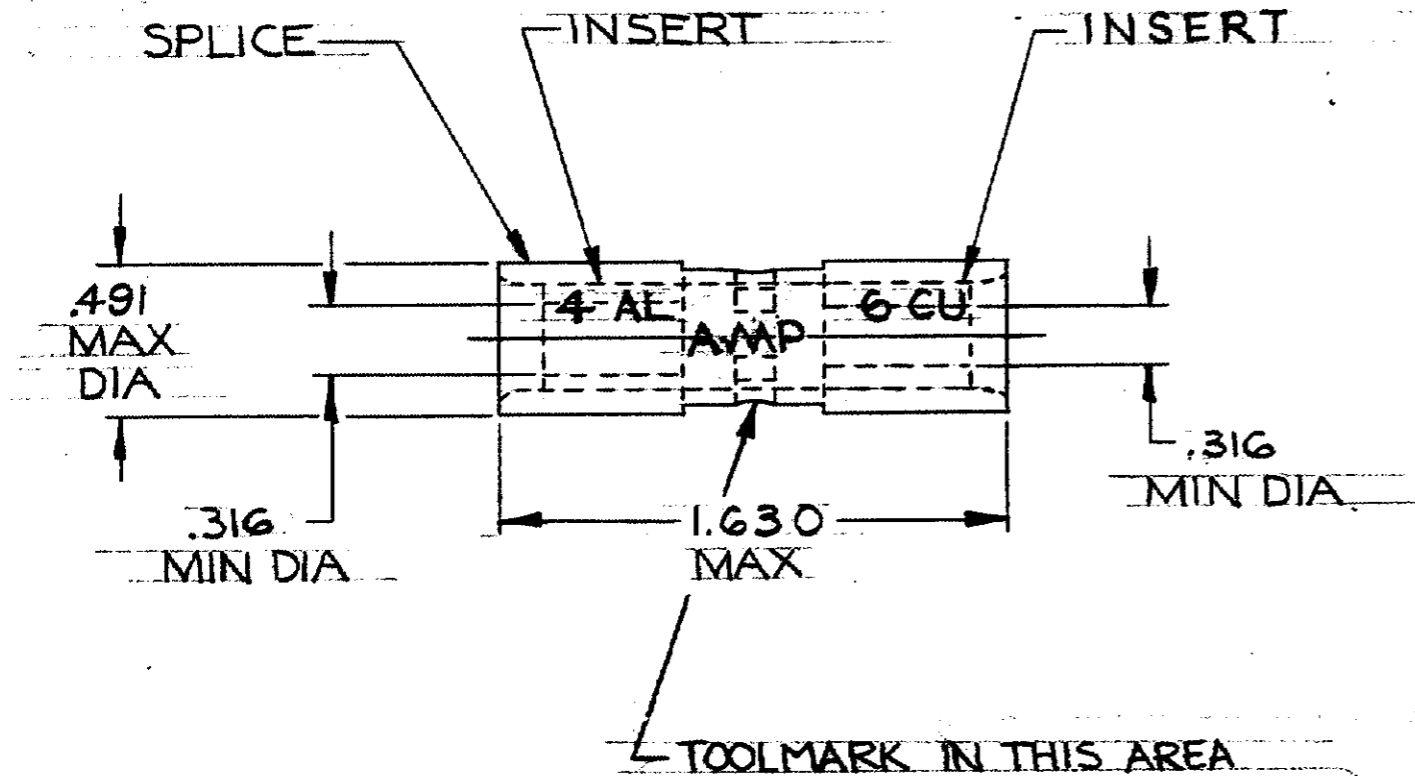

WIRE SPLICE		51942	INSERT: BRASS (MIL-C-50) TIN PL (MIL-T-10727) .0003 MIN EXT THK SPLICE: COPPER (QQ-C576) TIN PL (MIL-T-10727)
QTY	DESCRIPTION	PART NO.	MATERIAL & FINISH
	UNLESS OTHERWISE SPECIFIED DIM. ARE IN INCHES. TOLERANCES ON: DECIMALS ± .008 ANGLES ± 5°	CONTRACT NO. #	AMP AMP INCORPORATED HARRISBURG, PENNSYLVANIA
MATERIAL	SEE TABLE	DR <i>R. Chappell</i> 6-27-68 CHK <i>R. Wolfe</i> 7-1-68 APPD <i>Swabel</i> 7-2-69	NAME WIRE SPLICE COPALUM-STRANDED/SOLID WIRE SIZE: 4 TO 6
HEAT TREAT	#	DSGN APPD	SIZE B
FINISH	SEE TABLE	OTHER APPD	CODE IDENT NO. 00779
LOC <i>G-86</i>	PRINT DATE		NUMBER 51942
			SCALE 2:1
			WT CALC ACTUAL SHEET 1 OF 1